



Lower Thames Crossing
9.69 Draft Statement of
Common Ground between (1)
National Highways and (2)
Harlex Haulage and (3) J & B
Martin (Crayford & Fawkham)
Limited
(Tracked changes version)

Infrastructure Planning (Examination
Procedure) Rules 2010

Volume 9

DATE: ~~November~~ 2023
DEADLINE: ~~7~~

Deleted: August

Deleted: 3

Planning Inspectorate Scheme Ref: TR010032
Examination Document Ref: TR010032/EXAM/9.69

VERSION: ~~2~~ 0

Deleted: 1

Revision history

<u>Version</u>	<u>Date</u>	<u>Submitted</u>
<u>1.0</u>	<u>24 August 2023</u>	<u>Deadline 3</u>
<u>2.0</u>	<u>17 November 2023</u>	<u>Deadline 7</u>

Status of the Statement of Common Ground

This is a Draft Statement of Common Ground with matters outstanding.

National Highways considers that this draft Statement of Common Ground is an accurate description of the matters raised by Harlex Haulage Limited, and J & B Martin (Crayford & Fawkham) Limited and the status of each matter, based on the engagement that has taken place to date.

Deleted:

From: [REDACTED]

Sent: Monday, August 14, 2023 9:37 AM

To: [REDACTED]

Subject: RE: Harlex et al - SoCG Draft

Dear [REDACTED]

[REDACTED] wants a meeting to go through
I suggest that this one is submitted as a

Regards

[REDACTED]

[REDACTED]

Lower Thames Crossing

9.69 Draft Statement of Common Ground between (1) National Highways and (2) Harlex Haulage and (3) J & B Martin (Crayford & Fawkham) Limited (Tracked changes version)

List of contents

	Page number
1 Introduction	1
1.1 Purpose of the Statement of Common Ground.....	1
1.2 Parties to this Statement of Common Ground	1
1.3 Terminology	1
2 Matters	2
2.1 Movement of Outstanding matters.....	2
Appendix A Glossary	18
Appendix B Harlex Vehicle Tracking	19
Appendix C Harlex Further Design Request	21
Appendix D Park Pale Curb Profile	23

List of tables

	Page number
<u>Table 2.1 Matters</u>	<u>3</u>

Deleted: 1 Introduction 1¶
1.1 Purpose of the Statement of Common Ground 1¶
1.2 Parties to this Statement of Common Ground 1¶
1.3 Terminology 1¶
2 Matters 2¶
2.1 Outstanding matters 2¶
Appendix A Harlex Further Design Request 14¶
Appendix B Park Pale Curb Profile 15¶
Appendix C Glossary 16¶

Deleted: Table 2.1 Matters 2¶

1 Introduction

1.1 Purpose of the Statement of Common Ground

- 1.1.1 This Statement of Common Ground (SoCG) has been prepared in respect of the Development Consent Order (DCO) application for the proposed A122 Lower Thames Crossing (the Project) made by National Highways Limited (the Applicant) to the Secretary of State for Transport (Secretary of State) under section 37 of the Planning Act 2008 on 31 October 2022.
- 1.1.2 The SoCG has been produced to confirm to the Examining Authority where agreement has been reached between the Applicant and Harlex Haulage Limited, and J & B Martin (Crayford & Fawkham) Limited and where agreement has not been reached. Where matters are yet to be agreed, the parties will continue to work proactively to reach agreement and will update the SoCG to reflect areas of further agreement.
- 1.1.3 This version of the SoCG has been submitted at Examination Deadline 7,

Deleted: 3

1.2 Parties to this Statement of Common Ground

- 1.2.1 This SoCG has been prepared in respect of the Project by (1) National Highways, and (2) Harlex Haulage Limited, and J & B Martin (Crayford & Fawkham) Limited (referred to as 'Harlex' in the remainder of this document) .
- 1.2.2 National Highways became the Government-owned Strategic Highways Company on 1 April 2015. It is the highway authority in England for the strategic road network and has the necessary powers and duties to operate, manage, maintain, and enhance the network. Regulatory powers remain with the Secretary of State. The legislation establishing National Highways made provision for all legal rights and obligations of the Highways Agency, including in respect of the Project, to be conferred upon or assumed by National Highways.
- 1.2.3 Harlex possess Category 1 interests in plots 03-62, 03-68 and 03-79, as outlined in the Land Plans [REP5-006] and Book of Reference [REP5-030],

Deleted: [REP1-009] and Book of Reference [REP1-053].
....

1.3 Terminology

- 1.3.1 In the matters table in section 2.1, of this SoCG, "Matter Not Agreed" indicates agreement on the matter could not be reached following engagement, and "Matter Under Discussion" where these points will be the subject of ongoing discussion wherever possible to resolve, or refine, the extent of disagreement between the parties. "Matter Agreed" indicates where the issue has now been resolved.

Deleted: 2.1Error! Reference source not found.

Deleted: on-going

2 Matters

2.1 Movement of Outstanding matters

- 2.1.1 Engagement between the Applicant and Harlex Haulage Limited, and J & B Martin (Crayford & Fawkham) Limited has been ongoing since February 2020. These discussions are summarised in Annex B of the Statement of Reasons [REP5-028].
- 2.1.2 Following submission of Harlex Haulage Limited, and J & B Martin (Crayford & Fawkham) Limited's Relevant Representation, discussions on matters have taken place between the Applicant and landowners. These discussions will be summarised in subsequent updates to Annex B of the Statement of Reasons [REP5-028].
- 2.1.3 The outcome of discussions to date are presented in Table 2.1 which details and presents the matters which have been agreed, not agreed, or are under discussion between (1) the Applicant and (2) Harlex Haulage Limited, and (3) J & B Martin (Crayford & Fawkham) Limited.
- 2.1.4 At Deadline 3 there were 11 matters, one which was not agreed, eight under discussion and two agreed.
- 2.1.5 At Deadline 7 there are still 11 matters, two of which are not agreed, seven under discussion and two agreed.
- 2.1.6 Matter 2.1.10, Retained Land Access has been deleted following discussions with the agent where it was agreed that this matter should be treated separately as access is required by a different entity.
- 2.1.7 Matter 2.1.1 has now been split into two matters and so a new matter, 2.1.12, Agreements & Commitments, has been created from what was 2.1.1.

Deleted: [APP-060].

Deleted: [APP-060](#)

Table 2.1 Matters

Topic	Item No.	Harlex Haulage Limited, and J & B Martin (Crayford & Fawkham) Limited Comment	The Applicant's Response	Application Document Reference	Status
Documentation & Recording of Agreement					
<u>SoCG</u>	<u>2.1.1</u>	<u>Harlex has requested a Statement of Common Ground to be considered, stating the Applicant believes that a Voluntary Agreement and details to be submitted to a Commitments Register would be more appropriate. Harlex would question why a Statement of Common Ground would not be more appropriate. The Applicants response has been that they are offering private landowner commitments and a form of voluntary agreement to address various concerns. Provided the agreement and/or commitments are counter signed, they will transfer those internally and contractually to their future contractors to observe. Harlex would ask PINS to address the appropriateness of the Applicant's proposed actions having reviewed the proposed terms of the voluntary agreement and the non-object requirement.</u>	<u>The Applicant has acknowledged Harlex's request and is willing to enter a Statement of Common Ground (SoCG) to record the position given the absence of prior agreement and new issues that have been raised.</u> In respect of the Interested Party's comments on the 'non-object requirement', the Applicant wishes to clarify this was limited to the entrance and exit design and PRoW NS161 diversion only, and did not prevent objections to any other matter. The Applicant accommodated the Interested Party's design request at Community Impacts Consultation (June 2021) and proposed a commitment letter (which also includes implementation matters) so as to demonstrate landowner agreement should the (then new) design proposals encourage objections from third party's.		<u>Matter Agreed</u>

Deleted: <#>Subsequent versions of this SoCG will outline the changes between versions.¶

Moved (insertion) [2]

Moved (insertion) [3]

Topic	Item No.	Harlex Haulage Limited, and J & B Martin (Crayford & Fawkham) Limited Comment	The Applicant's Response	Application Document Reference	Status
<u>Agreements & Commitments</u>	2.1.12	<p>The interested party accepts that the additional design requirements should be included in the Commitments Register as well as an SoCG being entered into.</p> <p>The Applicant has stated that the design changes are at the landowners' request. The interested party would point out that due to the extent of the works associated with the project, the existing access would be lost/unworkable due to width restrictions and hence whilst this design change may be at the request of the landowner, it is a necessity in order for the haulage yard to continue and to prevent business extinguishment.</p> <p>Whilst heads of terms for an access easement to grant rights and design change has been provided by the Applicant, the terms offered were unacceptable with restriction on the balancing pond access restricted to agricultural use only and previously overage provisions were included in the terms and hence whilst the Applicant has stated that they have not received a response or agreement to the offered commitments, the terms were unacceptable and therefore it is disingenuous to imply that the interested party has not responded. Furthermore, the interested party has serious concerns that the</p>	<p>The Applicant's position to date has been focused on attempts to reach agreement on aspects which address <u>landowners'</u> concerns and seek to mitigate impacts. Provided agreement can be reached, the issue will then be resolved and a formal binding commitment will be transferred to contractors and an associated project manager lead to ensure compliance.</p> <p>In this case, the Applicant has accommodated design changes at the landowner's request and issued a letter to set out various commitments in relation to the delivery of replacement access. The Applicant has also sent Heads of Terms for an access easement to grant rights.</p> <p>To date, the Applicant has not received a response or agreement to these offered commitments.</p> <p>The Applicant responds specifically to the access easement under <u>item 2.1.8</u> below.</p> <p><u>The replacement access will be safe as full visibility will be provided in both directions at the junction. The replacement access has an exaggerated bellmouth for right hand turns onto Park Pale, and the entire bellmouth measures 32.3 metres. The level of the replacement access will tie in (at grade) to Park Pale and the Harlex site, and the Applicant has</u></p>	<p>General <u>Arrangement Plans</u> Volume B [REP4-031]</p>	Matter Not Agreed

Moved down [1]: SoCG

Moved up [2]: Harlex has requested a Statement of Common Ground to be considered, stating the Applicant believes that a Voluntary Agreement and details to be submitted to a Commitments Register would be more appropriate. Harlex would question why a Statement of Common Ground would not be more appropriate. The Applicants response has been that they are offering private landowner commitments and a form of voluntary agreement to address various concerns. Provided the agreement and/or commitments are counter signed, they will transfer those internally and contractually to their future contractors to observe.

Moved up [3]: The Applicant has acknowledged Harlex's request and is willing to enter a Statement of Common Ground (SoCG) to record the position given the absence of prior agreement and new issues that have been raised. ¶

Deleted: 1

Deleted: Harlex would ask PINS to address the appropriateness of the Applicant's proposed actions. ¶

Deleted: The Applicants

Deleted: landowners

Deleted: N/A

Deleted: section

Topic	Item No.	Harlex Haulage Limited, and J & B Martin (Crayford & Fawkham) Limited Comment	The Applicant's Response	Application Document Reference	Status
		<p><u>proposed alternative access to be provided will be suitable for the unrestricted use of the yard and the interface with other traffic from the golf club. The interested party has no confidence that the levels and sweep paths will work to enable a safe and viable entrance and exit to the Harlex yard. The Applicant must commit to guaranteeing it is safe and will work within the Design Principles. In addition, the Applicant must commit to providing a design that is workable for the unrestricted use of the haulage yard where the access turns left off Park Pale Road up the incline to the new entrance and that this meets all necessary design requirements.</u></p>	<p><u>proposed a design accommodation commitment to address tie in works, as mentioned at item 2.1.4 below.</u></p> <p><u>The Applicant has also undertaken vehicle tracking and shared the same with Harlex demonstrating articulated vehicles, measuring 16.48m in length, can navigate the replacement access as delineated on Sheet 3 of the General Arrangement Plans.</u></p> <p><u>In respect of the Interested Party's as to workable design from Park Pale up the incline to the new entrance, the junction on Park Pale is of a similar geometric design to the geometry of the junction between Park Pale and Brewers Road, which is regularly used by Harlex vehicles currently.</u></p> <p><u>As this is not a private right of way, the implementation of works falls under article 10(1) of the draft DCO. Therefore, these works will be required to be completed to the reasonable satisfaction of KCC as the statutory highway authority responsible for Park Pale. It should be noted that article 10 of the draft DCO is to be read together with Schedule 14, Part 11 of the draft DCO (Protective Provisions for Local Highway Authorities)</u></p>		

Topic	Item No.	Harlex Haulage Limited, and J & B Martin (Crayford & Fawkham) Limited Comment	The Applicant's Response	Application Document Reference	Status
			<u>[REP6-010] which provides a robust and prescribed process whereby the Applicant would be required to remedy any defects identified by KCC as local highway authority. It should also be noted that clause 150(2)(a) of Schedule 14, Part 11 of the draft DCoO requires a stage 3 road safety audit to have been carried. The Applicant therefore considers that it has already committed to providing a design that will be workable and would be to the satisfaction of KCC as the relevant Highway Authority.</u>		
Design					
Balancing Pond	2.1.2	Harlex were unhappy with the original balancing pond design and requested it to be moved further east.	The Applicant accommodated this design request before Supplemental Consultation (January 2020) and the balancing pond Work No 11 as shown on Sheet 3 of the Works Plans is now further east than it was originally proposed.	<u>Works Plans Volume B Composite [REP4-038]</u>	Matter Agreed
Replacement Access Updated Entrance & Exit Design Request	2.1.3	Harlex propose a new updated entrance and exit design for the replacement access. <u>The reason for this request was that there was no alternative and that the Applicant had not appreciated the design requirements during early design.</u> <u>The interested party remains sceptical the sweep paths and vehicle tracking will work</u>	The current design (Work No 1C as shown on Sheet 3 of the Works Plans) was proposed by Harlex and accommodated by the Applicant at Community Impacts Consultation (June 2021). The Applicant has undertaken vehicle tracking and shared the same demonstrating articulated vehicles measuring 15.5m in length, can navigate	<u>Works Plans Volume B Composite [REP4-038]</u>	Matter Not Agreed

Deleted: Works Plans [\[AS-024\]](#)

Deleted: .

Deleted: -

Deleted: Works Plans [\[AS-024\]](#)

Deleted: HGV's

Topic	Item No.	Harlex Haulage Limited, and J & B Martin (Crayford & Fawkham) Limited Comment	The Applicant's Response	Application Document Reference	Status
		<p><u>in practice from Park Pale Road and into the haulage yard</u></p>	<p>the replacement access in its current design. Please refer to Appendix 1. This further request to change the design, as illustrated in Appendix 2, received on 7 February 2023, will have many impacts and the Applicant has a number of design concerns over the design of the access proposed by Harlex. Splitting the carriageway until the junction will lead to vehicles entering and exiting the junction on the wrong side of the road (as Harlex switch their direction of one way operation), which would be a safety risk. The current design ensures that all vehicles are on the correct side of the carriageway at the junction. As the access will also be used by the Applicant for maintenance of ponds, it would also mean that maintenance vehicles would either have to travel against the flow of traffic or go through the Harlex site to avoid conflict. Splitting the carriageway also means pedestrians using the footpath will have to cross two carriageways, which is avoided in the current proposal. It may also need to be consulted on and will incur additional cost (compared to current design) and introduce consultation uncertainty.</p>		

Deleted: A,

Deleted: to change the design

Deleted: carriageway's

Topic	Item No.	Harlex Haulage Limited, and J & B Martin (Crayford & Fawkham) Limited Comment	The Applicant's Response	Application Document Reference	Status
			<p><u>The replacement access to Harlex Haulage is a private/maintenance access track; therefore, it does not fall under the requirements of the Design Manual for Roads and Bridges (DMRB). However, to promote a conservative design approach at this stage of preliminary design, DMRB CD 123 recommendation at clause 5.2 has been considered: "Allowance shall be made for the swept turning paths of the worst case design vehicle which is expected to use the priority junction."</u></p> <p><u>The worst case scenario was not available at the time of the design; therefore, a standard design vehicle has been used in accordance with DMRB CD 123, which states: "The design vehicle for at-grade priority and signal controlled junctions is a 16.5m long articulated Heavy Goods Vehicle."</u></p> <p><u>As noted under clause 5.6.2 in DMRB CD 123: "At simple priority junctions where provision is made for the design vehicle, the corner radii should be 15 metres in</u></p>		

Topic	Item No.	Harlex Haulage Limited, and J & B Martin (Crayford & Fawkham) Limited Comment	The Applicant's Response	Application Document Reference	Status
			<p><u>rural areas followed by a corner taper of 1:10 over a distance of 25 metres.</u></p> <p>The uses of this junction will be limited to Harlex Haulage and National Highways maintenance vehicles only. Members of the public and general road users should not be using this access; therefore, this is a private means of access. As this junction does not sit on the Strategic Road Network nor form a through route the design has been developed to safely fit within the surrounding constraints.</p> <p>With all the considerations above, it is therefore concluded that the design of the access to Harlex is safe and in line with good practice and current standards.</p>		
Replacement Access – Tie in works	2.1.4	<p>Harlex suggest there would be level issues with ensuring the new access ties into the site</p> <p><u>The previous draft proposals provided by the Applicant need to be updated and take account of the further meetings held since April 2021.</u></p>	<p>The Applicant's design accommodation letter for the replacement access road specifically deals with this issue and mitigates disruption. This was issued on 1 April 2021 with subsequent reminders. The Applicant will update and recirculate the design accommodation letter for the landowner to sign and return, so it can transfer the commitments therein to Contractors and an associated Project Manager lead to ensure compliance.</p>	N/A	Matter Under Discussion

Deleted: -

Deleted: has urged

Deleted: this letter

Topic	Item No.	Harlex Haulage Limited, and J & B Martin (Crayford & Fawkham) Limited Comment	The Applicant's Response	Application Document Reference	Status
Replacement Access – fencing & gates	2.1.5	<p>Harlex request replacement security gates at the entrance to their Yard and fencing to the northern extent of the new access road to prevent the general public and their dogs from roaming into the new Harlex haulage yard for health and safety purposes. The interested party insists that any accommodation works should provide sufficient security measures as exist at present and expect that commitment from the Applicant.</p> <p><u>Detailed specifications of security gates are difficult to provide when the project is not at detailed design stage. The commitment from the Applicant should be to ensure that security and safety is no less than exists.</u></p>	<p>Please refer to the General Arrangement Plans (specifically sheet 3), which shows fencing is to be installed on the northern boundary.</p> <p>In respect of new entrance gates, the Applicant has requested further details from the landowner as to their proposed positioning. The Applicant also requests further details and specifications for the current gates that Harlex utilise at the existing entrance and exit. Following receipt of this information the Applicant will consider the landowners request further and if agreed, a private commitment can be entered. In absence of express agreements or commitments, the Applicant would like to state that the draft DCO obliges the Applicant to restore land to the reasonable satisfaction of the owner (draft DCO, Article 35).</p>	<p><u>General Arrangement Plans Volume B [REP4-031]</u> <u>Draft DCO [REP6-010]</u></p>	Matter Under Discussion
Park Pale curb profile	2.1.6	<p>Harlex have requested a continuous curb profile as Park Pale road diverts to provide access to the Harlex yard and the Golf Club to deter people parking and congregating in the T part .</p> <p><u>The interested party requires the Applicant to take responsibility for the consequences that will arise from the design changes of Park Pale Road (which is for access only)</u></p>	<p>The Applicant is willing to consider this request, dated 7 February 2023, to make the T junction a continuous curb profile as per previously circulated sketch, which can be seen in Appendix 3. However, the Applicant would like to prompt Harlex to consider this request further. The current design allows vehicles to turn around on Park Pale before they get to the turn heading to the overbridge. If this is</p>	N/A	Matter Under Discussion

Deleted: General Arrangement Plans (Volume B) (Sheets 1 to 20) [APP-016]
Draft DCO [REP1-042]

Deleted:)

Deleted: B

Topic	Item No.	Harlex Haulage Limited, and J & B Martin (Crayford & Fawkham) Limited Comment	The Applicant's Response	Application Document Reference	Status
		<p><u>and agree with KCC Highways that better signage should be erected at the entrance to park Pale Road and also insist that both sides of the road are painted with double yellow lines.</u></p>	<p>removed, and a continuous curb profile is implemented, there is a risk that more vehicles could try and turn around in the carriageway causing more disruption to Harlex and road users.</p> <p>The Applicant requests confirmation from Harlex whether they want the Applicant to proceed with considering this design request through its governance process, in light of the above comments.</p> <p>The Applicant would like to emphasise that the DCO application as submitted contains sufficient provisions in which this curb profile request can be considered and accommodated at the detailed design stage, following consultation with all of the relevant parties (including Kent County Council as highway authority).</p> <p><u>In respect of Park Pale and traffic enforcement, the Applicant has relayed Harlex's concerns to Kent County Council who are aware and will continue to monitor the issues presented by local landowners. Kent County Council advise Park Pale has an existing Traffic Regulation Order and signage has been renewed since the Applicant first relayed local landowner concerns. Kent County Council have also advised, by way of</u></p>		

Topic	Item No.	Harlex Haulage Limited, and J & B Martin (Crayford & Fawkham) Limited Comment	The Applicant's Response	Application Document Reference	Status
			<p><u>email dated July 2021, "In regards to including double yellow lines in the LTC proposals, we agreed it was not something that should be included as there is work underway to hopefully resolve the issue through other means and if it was deemed that double yellows were required, then KCC as the highway authority would look to install these".</u></p> <p><u>The Applicant notes however that Part 3, Streets, article 10 of the draft DCO states:</u></p> <p><u>"Construction and maintenance of new, altered or diverted streets and other structures</u></p> <p><u>10.—(1) Subject to paragraphs (3) and (4), any highway (other than a trunk road or a special road) to be constructed under this Order must be completed to the reasonable satisfaction of the relevant local highway authority in whose area the highway lies and, unless otherwise agreed in writing with the relevant local highway authority, the highway, including any culverts or other structures laid under it, must be maintained by and at the</u></p>		

Topic	Item No.	Harlex Haulage Limited, and J & B Martin (Crayford & Fawkham) Limited Comment	The Applicant's Response	Application Document Reference	Status
			<u>expense of the relevant local highway authority from its completion."</u>		
Park Pale anti-social behaviour	2.1.7	<p>Harlex has significant concerns regarding the design of Park Pale Road and the proposed cycleway (3metres wide) as the design will exacerbate the anti-social behaviour that occurs in the locality.</p> <p>The area under the existing Park Pale overbridge will be used as a shelter and refuge point for anti-social behaviour. The Interested Party would like access restrictions from Park Pale to the new cycle path to prevent it being used as a road.</p> <p>Whilst the Applicants Design Principles may be followed and it is suggested that robust design elements will be provided to prevent and mitigate the potential for misuse, no details have been provided to the interested party as to what those robust design elements will consist of.</p>	<p>The cycle route will be designed in accordance with the Applicant's Design Principles.</p> <p>Please refer to Design Principles, table 4.1, in particular PEO.01 – PEO.06. The Project must be designed in accordance with these principles, which will become legal requirements if the DCO is consented.</p> <p>Of particular emphasis to the landowners anti-social behaviour concern, PEO.06 includes express consideration of <i>"robust design elements to prevent and mitigate the potential for misuse...by unauthorised vehicles and to prevent and deter anti-social behaviour"</i>.</p> <p>The Applicant would direct the Interested Party to paragraph 2.1.7 of the Design Principles which explains how they are secured in the delivery of the Project. The Design Principles are secured in Schedule 16, via Requirement 3 and Requirement 5 in Schedule 2 of the draft Development Consent Order. It would further comment that the Design Principles strive to create a collaborative working towards detail design elements with all interested parties (including Kent</p>	<p><u>Design Principles</u> [REP6-046]</p> <p><u>Draft Development Consent Order</u> [REP6-010]</p>	Matter Under Discussion

Deleted: Applicants

Deleted: 7.5 Design Principles **[APP-516]**
3.1 Draft Development Consent Order [REP1-042]

Deleted: [REP1-042].

Topic	Item No.	Harlex Haulage Limited, and J & B Martin (Crayford & Fawkham) Limited Comment	The Applicant's Response	Application Document Reference	Status
			County Council for matters of WCH routes).		
Ownership and Rights					
Access Easement within plots 03-53 and 03-84	2.1.8	<p>Harlex require rights to use the replacement access road into their Yard and retained land.</p> <p>The Applicant makes reference to the heads of terms for an access easement and the suggestion that the interested party has not responded is disingenuous. The interested party cannot agree to the current heads of terms which restrict access to agricultural use to the retained land and therefore the current heads of terms are not fit for purposes.</p> <p><u>The interested party is not agreeable to the current heads of terms. Further negotiations are required in order to reach agreement.</u></p>	<p>The Applicant is aware that one of Harlex's co-owners has recently acquired title to the retained, or adjoining land to the east. Following discussions with the agent, the Applicant understands that this land should be treated separately as access is required by a different entity. Therefore, references to this land are to be disregarded and deleted from this SoCG.</p> <p>The Applicant has prepared Heads of Terms (HoTs) for an access easement for the new replacement road, and access to adjoining land. These were first circulated to the previous landowner (who has the same agent as Harlex) on 24 February 2021. The latest version (version 4) of the Heads of Terms (HoTs) were sent on 27 May 2021, and resent on 22 December 2022. The HoTs in circulation is currently revision 4.</p> <p>Since May 2021, the Applicant has received no response. The Applicant would welcome agreement to the Heads of Terms in order to instruct solicitors to prepare a draft, ready for execution once the replacement road is constructed and</p>		Matter Under Discussion

Deleted:)

Deleted: Harlex

Moved (insertion) [1]

Deleted: retained

Deleted: HoT's

Deleted: HoT's

Topic	Item No.	Harlex Haulage Limited, and J & B Martin (Crayford & Fawkham) Limited Comment	The Applicant's Response	Application Document Reference	Status
			<p>operational, although the Applicant notes the Interested Party's preference to own the freehold, expressed at item 2.1.9 below and received on 29th October 2023 as part of updating this SoCG. The Applicant will therefore consult its operational teams with a view to restructuring the terms to transfer title of the replacement access road reserving rights for the Applicant's use of the balancing pond road.</p> <p>With respect to the Interested Party's statement on the restriction on user access, the Applicant can confirm that there would be no limitation on the extent of replacement access to the Harlex business. The pavement is designed according to highway use, similar to Park Pale.</p>		
Ownership	2.1.9	<p>Harlex have enquired about the potential for owning the new road.</p> <p><u>The interested party's preference is to own the freehold of the access and grant rights to the Applicant, but security measures must be agreed to safeguard the interested party's property.</u></p>	<p>The Applicant's working case is that it will own the new replacement access road and balancing pond road over plots 03-53 and 03-84, and grant rights to Harlex.</p> <p>The Applicant is willing to consider transferring ownership of the new access road to Harlex, subject to reserving rights for its own access requirements to the balancing ponds.</p> <p><u>Following confirmation of the Interested Party's preference to own the freehold,</u></p>	N/A	Matter Under Discussion

Deleted: .

Deleted: ¶

The land neighbouring Harlex is green belt and understood to be used for agriculture. ¶
 Harlex have not particularised why they require unrestricted access to the east of their site over the extent of the Applicants balancing pond road, the Applicant considers that the access that has been proposed is sufficient for Harlex to access their site, particularly in light of Harlex not outlining why unrestricted access to the balancing pond road is necessary. However, as outlined below at 2.1.10, the Applicant considers that the articles in the Order would provide scope to enable a private access to the retained land to be installed if required. The Applicant is willing to consider providing access to the balancing ponds access road subject to further discussions with Harlex.

Deleted: Applicants

Deleted: National Highways

Topic	Item No.	Harlex Haulage Limited, and J & B Martin (Crayford & Fawkham) Limited Comment	The Applicant's Response	Application Document Reference	Status
			The Applicant <u>will</u> liaise with National Highways operations to consider appropriateness and terms, <u>before commencing discussions with Harlex on the mechanics of transfer.</u>		
Utility and Services	2.1.10	<p>The interested party has serious concerns over the interruption to existing critical utilities and services that are required in order for business continuity. There is also concern over drainage and surface water and design arising from the new access which will be constructed and will slope down towards the yard whereas the current access is from level ground and then leads up into the yard.</p> <p>As with the proposed access and security issues, all other services and necessary designs should be included within the commitments register to safeguard the future use of this important commercial business.</p>	<p>The Applicant notes this was not mentioned in the Interested Party's relevant representation although has been a topic that was discussed between the parties at a site meeting on 28 October 2020.</p> <p>In respect of drainage, the Applicant would refer to its DCO documents, and in particular its Works Plans (sheet 3 composite), which show the proposed work number labels. Work No. 11, in the draft DCO, includes "<i>construction of a new drainage infiltration basin with associated drainage facilities</i>". The Design Principles at LSP.28, state "<i>conveyance of runoff would be by means of drainage ditches / swales and pipes</i>".</p> <p>As noted above, the Design Principles strive to create a collaborative working towards detail design elements with all interested parties.</p> <p>In respect of utilities, the utility companies will continue to operate, complete and manage their works and works to their network in accordance with their own statutory obligations. The Applicant will work with the respective company to</p>	<p>Works Plans Volume B, Composite, [REP4-038] Draft Development Consent Order [REP6-010] Design Principles [REP6-046]</p>	<p>Matter Under Discussion</p>

Deleted: asks Harlex to outline their preferred ownership position so that it can

Deleted: Retained Land Access ...

Deleted: 11

Deleted: (

Deleted:)

Deleted:)

Deleted: [\[APP-019\]](#)
Draft Development Consent Order (Deadline 1 Submission
[\[REP1-042\]](#)
7.5 Design Principles [\[APP-516\]](#)

Topic	Item No.	Harlex Haulage Limited, and J & B Martin (Crayford & Fawkham) Limited Comment	The Applicant's Response	Application Document Reference	Status
			<p>design, programme and manage the necessary works in a manner that mitigates those potential impacts to the customers of those networks. These provisions are secured by the relevant utility companies within their Protective Provisions at Schedule 14 Part 1, Part 2, Part 5, Part 6 and Part 7 of the draft DCO.</p> <p>The Applicant expects that no interruption to the supply of services will be proposed during Harlex's normal operating hours however any planned works that may result in interruption to services will be notified in advance of the works commencing at the detailed design and planning stage.</p>		

Deleted:Page Break.....

Appendix A Glossary

Term	Abbreviation	Explanation
Development Consent Order	DCO	<u>Legal instrument</u> obtaining permission for developments categorised as Nationally Significant Infrastructure Projects (NSIP) under the Planning Act 2008.
Heads of Terms	HoTs	Heads of terms are a document setting out the main terms of <u>an</u> agreement reached between parties.

Deleted: <#>.....Section Break (Next Page).....
Harlex Further Design Request
Harlex Further Design Request
.....Page Break.....
¶
Park Pale Curb Profile
.....Page Break.....
¶

Deleted: Heavy Goods Vehicle

Deleted: Means of

Deleted: a

Appendix B Harlex Vehicle Tracking

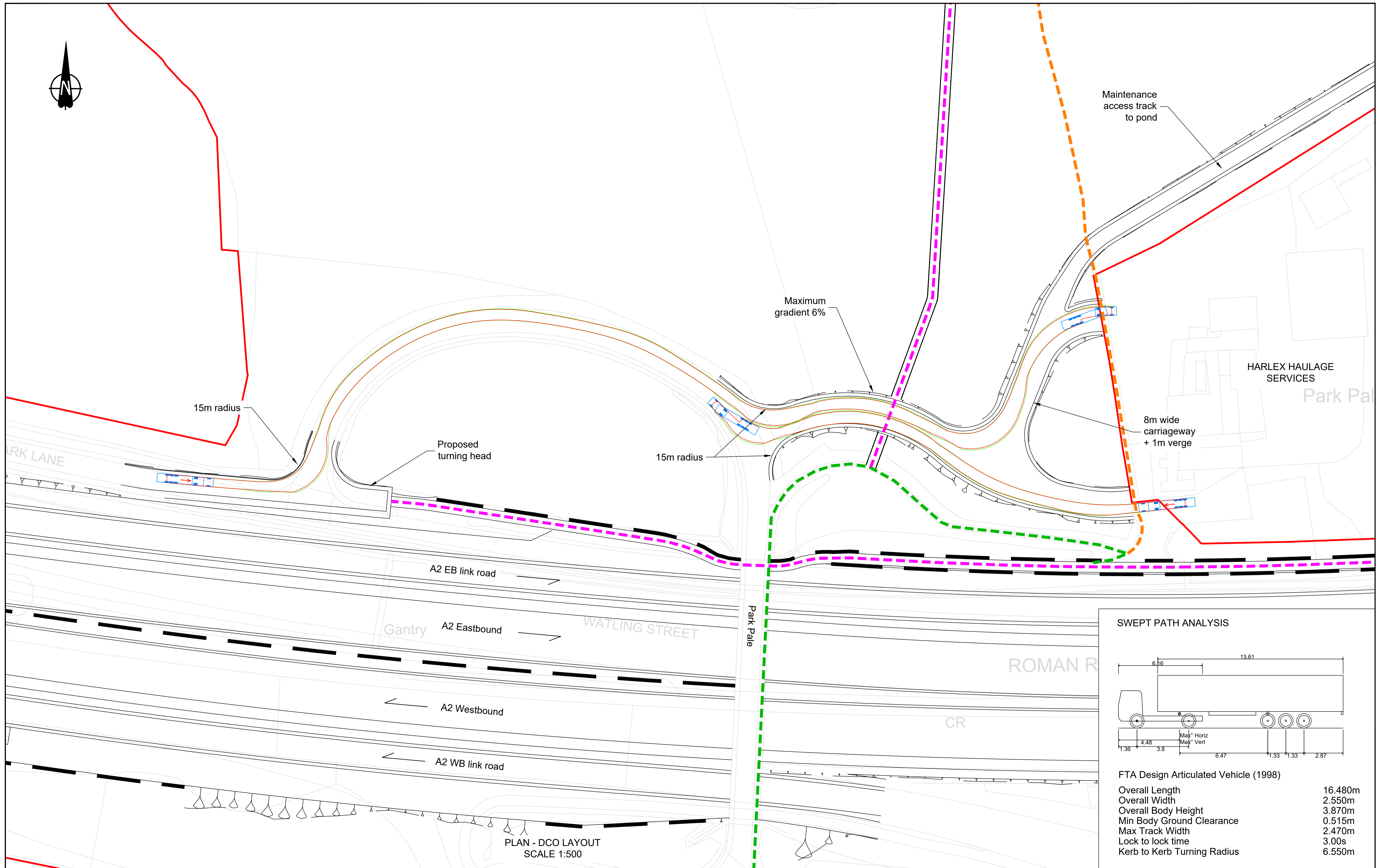

PLAN - DCO LAYOUT
SCALE 1:500

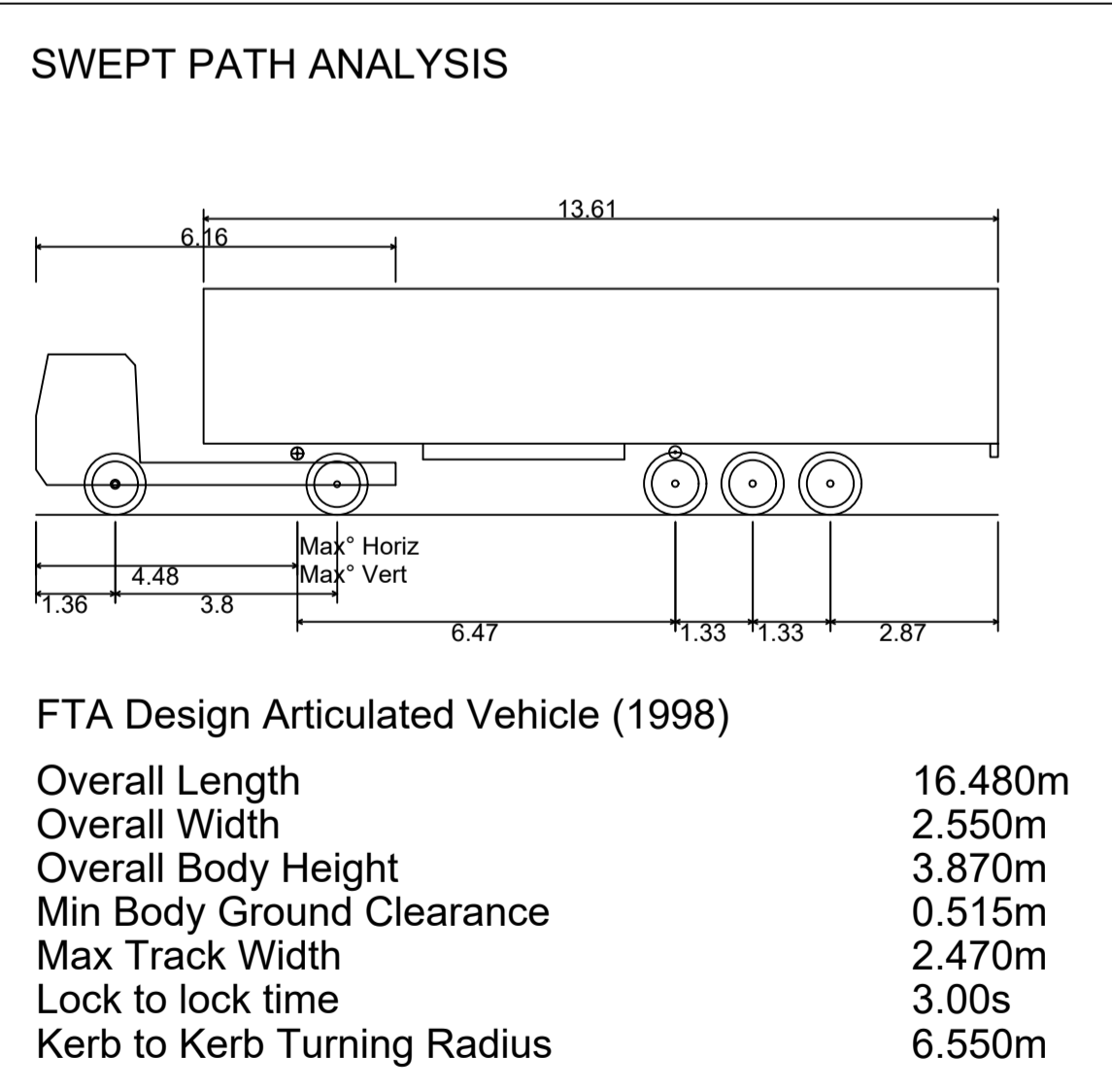

Contains Ordnance Survey data. © Crown copyright and database rights 2022. Ordnance Survey 100030649

P01.3	S2	07/11/2023	GC1	BB		
Rev	Status	Rev. Date	Purpose of revision	Drawn	Check'd	Apprv'd

KEY - PLAN

	OS Map		DCO boundary		Existing NMU retained
	Proposed layout		Swept path - tyres		Existing NMU stopped
	Retaining walls		Swept path - overhang		New proposed NMU

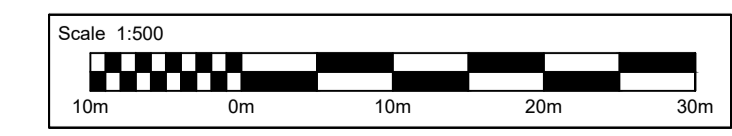

Client

Project

LOWER THAMES CROSSING

Status	Fit for Information	Original Size	A1	Revision	P01.3
Application Document Number	Scale 1:500				
Drawing title	Harlex Haulage Access Vehicle Tracking				
Drawing Number	HE540039-CJV-BOP-ZZZ_ZZZZZZZZZZ-DR-CH-00003				

Appendix C Harlex Further Design Request

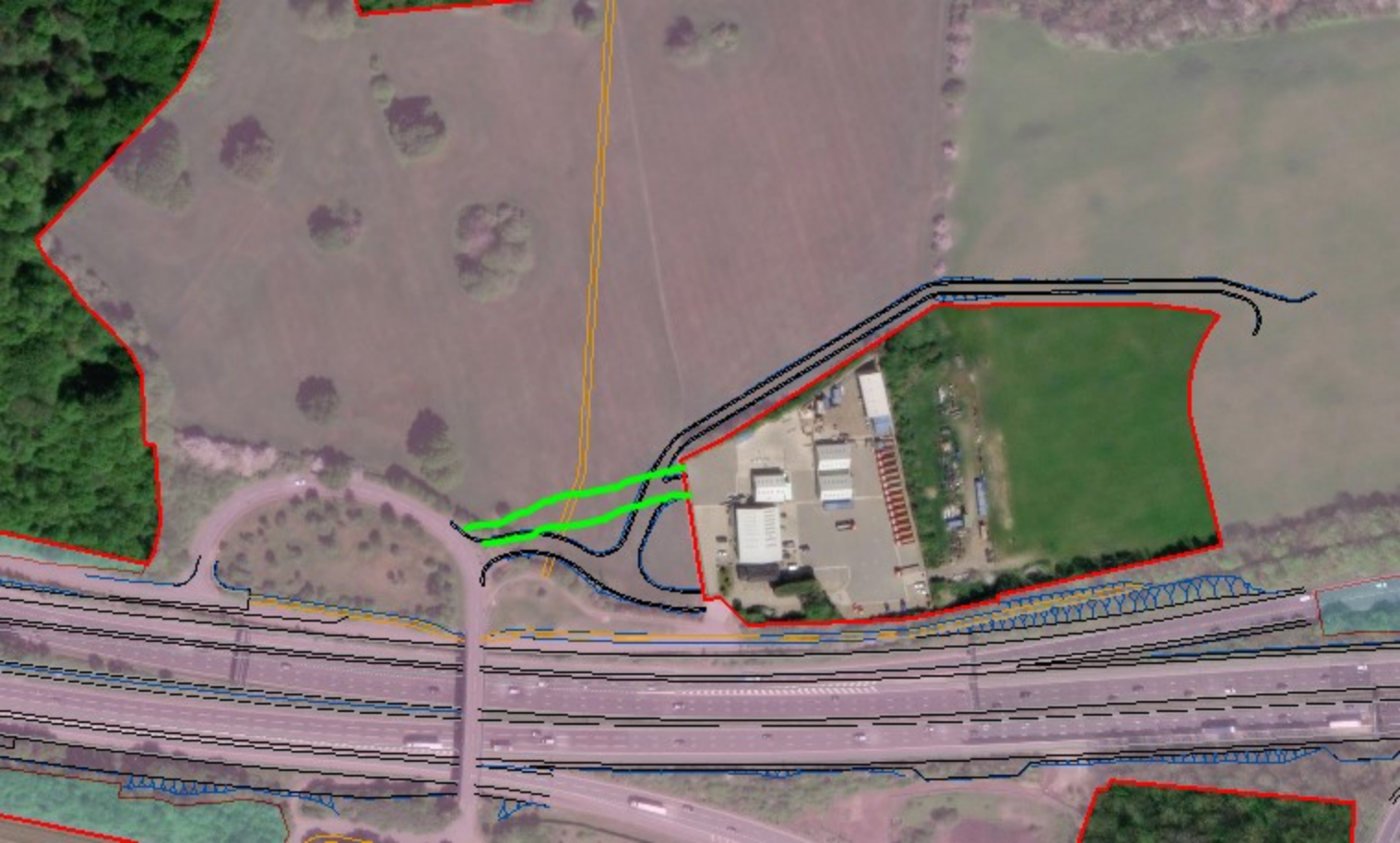

Appendix D Park Pale Curb Profile



If you need help accessing this or any other National Highways information, please call **0300 123 5000** and we will help you.

© Crown copyright 2023.

You may re-use this information (not including logos) free of charge in any format or medium, under the terms of the Open Government Licence. To view this licence:

visit www.nationalarchives.gov.uk/doc/open-government-licence/

write to the **Information Policy Team, The National Archives, Kew, London TW9 4DU** or email psi@nationalarchives.gsi.gov.uk

Mapping (where present): © Crown copyright and database rights 2023 OS 100030649. You are permitted to use this data solely to enable you to respond to, or interact with, the organisation that provided you with the data. You are not permitted to copy, sub-licence, distribute or sell any of this data to third parties in any form.

If you have any enquiries about this publication email info@nationalhighways.co.uk or call **0300 123 5000**.*

*Calls to 03 numbers cost no more than a national rate call to an 01 or 02 number and must count towards any inclusive minutes in the same way as 01 and 02 calls.

These rules apply to calls from any type of line including mobile, BT, other fixed line or payphone. Calls may be recorded or monitored.

Printed on paper from well-managed forests and other controlled sources when issued directly by National Highways.

Registered office Bridge House, 1 Walnut Tree Close, Guildford GU1 4LZ

National Highways Limited registered in England and Wales number 09346363